

FAMATEC FRIENDLY FR-V Plus

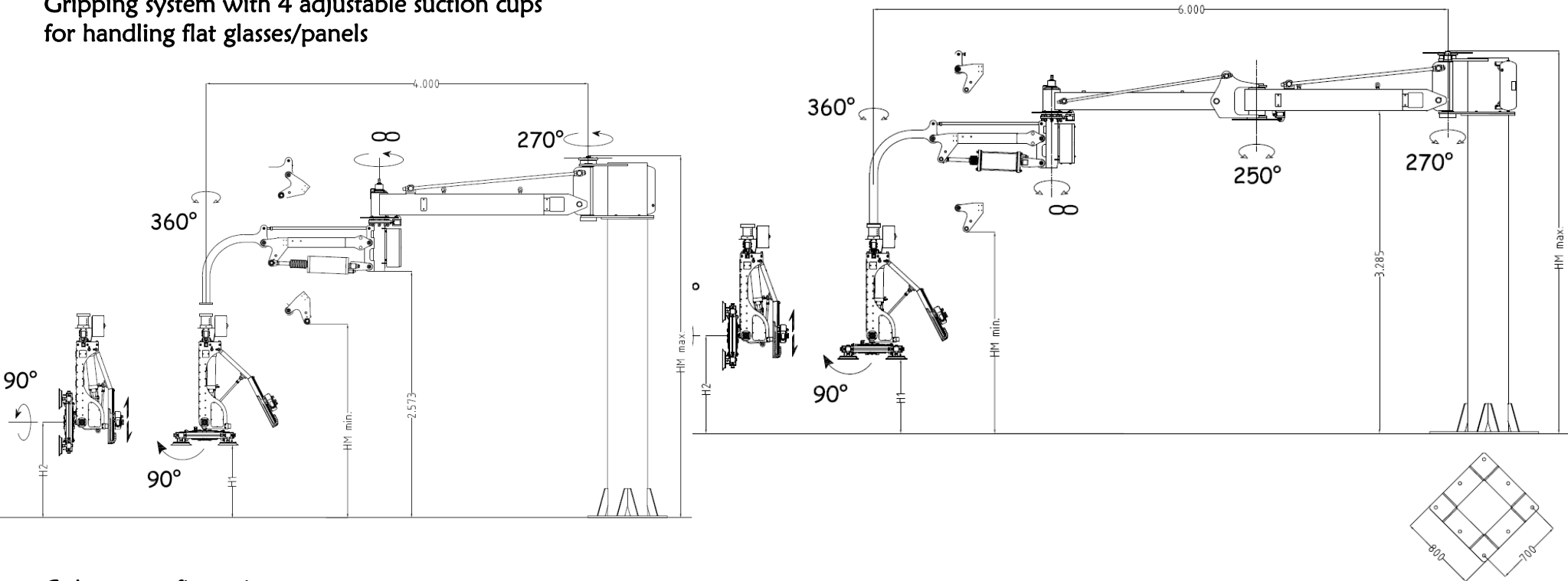

Gripping system with 4 adjustable suction cups for handling flat glasses/panels



Column configuration

Brakes on all rotation axes.
Suction pads can be quickly adjusted.
Console quickly adjustable in height.

Features:
Pneumatic tilting 90°
Pneumatic rotation 90°

Load capacity (Kg/lbs.)	Nominal Radius (mm/ft.)	H1 (mm/in.)		H2 (mm/in.)		HM (mm/in.)		Products min. dimensions (mm/in.)
		Min.	Max.	Min.	Max.	Min.	Max.	
150/330	4.000/13	60/3	1.460/57	340/13	1.650/65	2.050/81	4.000/157	1250x500/49x20 ^[1]
150/330	6.000/20	60/3	1.460/57	420/17	1.650/65	2.050/81	4.000/157	1250x550/49x22 ^[2]
250/550	4.000/13	60/3	1.460/57	550/22	1.650/65	2.050/81	4.000/157	1250x550/49x22 ^[2]
250/550	6.000/20	60/3	1.460/57	550/22	1.650/65	2.050/81	4.000/157	1250x550/49x22 ^[2]

^[1] 800x600 (31x24 in.) with quick adjustable suction pads kit 1600x250 (63x10 in.) with aligned suction pads
^[2] 1250x300 (49x12 in.) gripping with 2 suction cups. Load capacity -> 125 Kg. (275 lbs.)

- For fixing the column to the floor, a floor slab class C20/25 (ENV 206) with minimum thickness of 200mm (8 in.) is needed.

