

FAMATEC GINGO

Gripping system with 4 adjustable suction cups for handling and fitting flat glasses and windows.

- Moving on wheels with low friction and brakes.
- Balanced movement with weight pre selector.
- Including battery operated compressor, batteries and charger.

Features:

- Pneumatic tilting +/- 10°
- Frontal manual rotation 180°
- Axial rotation 180° (to get through doors while gripping the panel)
- Manual side movement +/-80mm (3 in.)

GINGO 250:

- Machine weight: 430 kg (948 lbs.)
- Easily dismountable, each piece weighs max. 50 kg (110 lbs.)

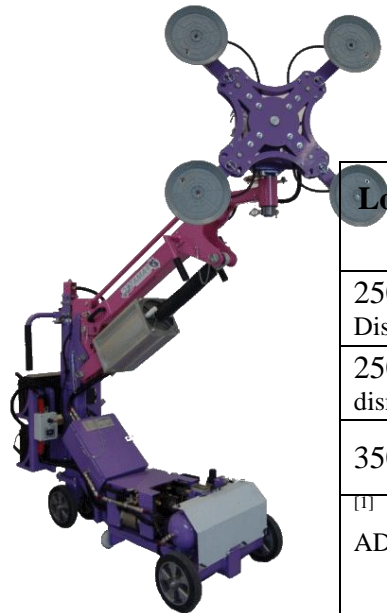

GINGO 350:

- Machine weight: 530 kg (1168 lbs.)
- Max. Load capacity 350kg (770 lbs.)

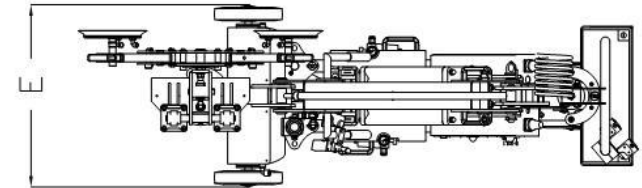
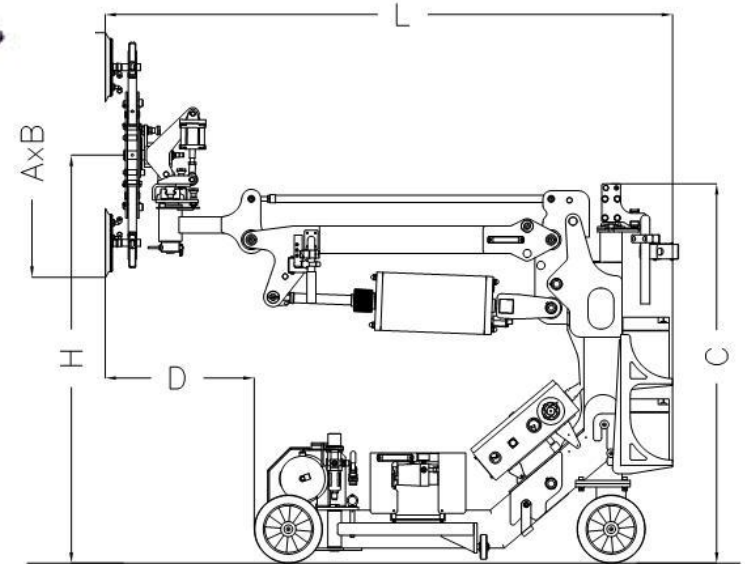

Load capacity Kg/lbs.	Hmin mm/in	Hmax mm/in	AxB mm/in	AxB mm/in	C mm/in	Dmin mm/in	Dmax mm/in	E mm/in	Lmin mm/in	Lmax mm/in
250 Dismountable	780/30	2.200/86	900x900 / 35x35	1.050x550 /41x21	1.400/55	290/11	540/21	700/27	1.850/73	2.100/83
250 Not dismountable	780/30	2.200/86	900x900 /35x35	1.050x550 /41x21	1.400/55	290/11	540/21	700/27	1.850/73	2.100/83
350 ^[1]	850/33	2.250/88	1.150x1.150 /45x45	1.350x650 /53x25	1.500/59	310/12	560/22	700/27	1.890/74	2.150/85

^[1] 8 bar (116 psi.) air pressure required

ADDITIONAL OPTIONS: - Aluminium platform for the loading and manual windlass for the loading

- Removable front arm extension

- Customized painting

- Exclusion of the two lower suction pads - max. lifting height middle suction pads 2.700mm/106 in. (max. load 50%)

FAMATEC FR-L