

Gripping system with one suction pad for handling sacks or carton boxes

Column configuration

Suction pad for handling sacks or boxes in horizontal position.

Turn the handles for activate and deactivate the suction pad.



Grip - release

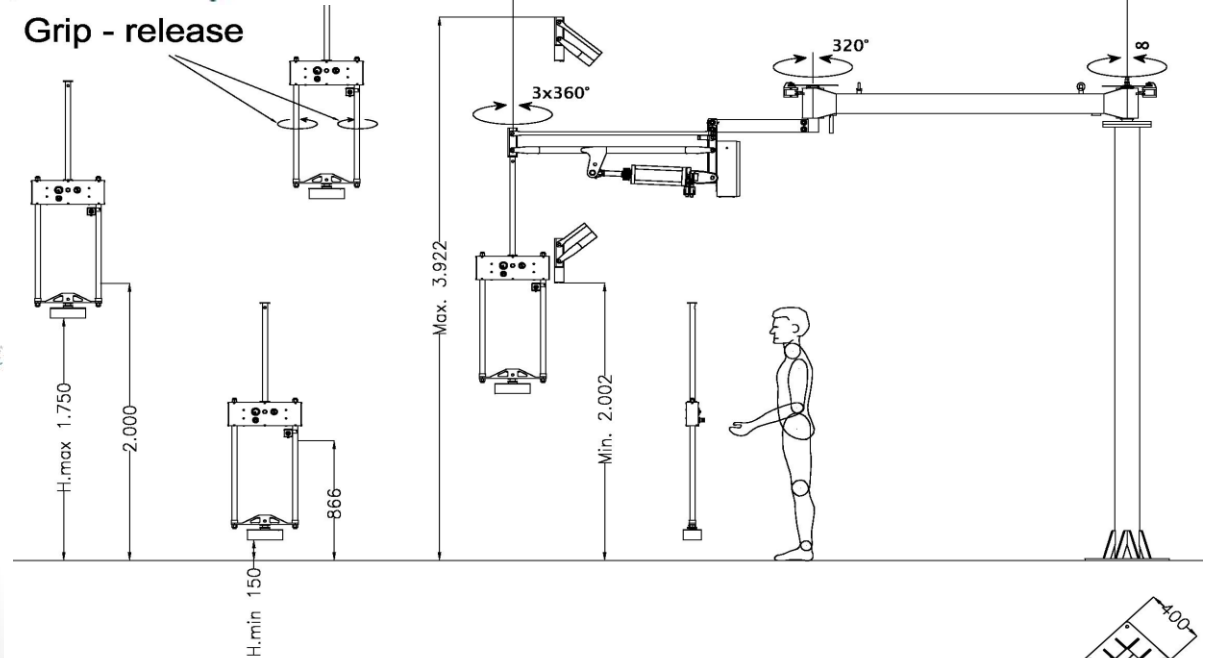

Model	Nominal Radius [m/ft.]	Load capacity [kg/lbs.]	HMin [mm/in.]	HMax [mm/in.]	Products min. dimensions [mm/in.]
Vaquo S	3/9.84	50/110	150/5.9	1.750/68	200x350/8x14
Vaquo S	4/13.12	50/110	150/5.9	1.750/68	200x350/8x14
Vaquo S	5/16.4	35/77	150/5.9	1.750/68	200x350/8x14

0,7 MPa (7bar) air pressure required, required airflow about 300NI/min.

Samples of the sacks are required for testing the gripping of the products.

For fixing the column to the floor a floor slab class C20/25 (ENV 206) with minimum thickness of 200mm, is needed.